

Three-jaw gripper with center thru hole and T-slot guide

Central thru hole can be used for:
 Parts inspection with camera
 Parts ejection with linear cylinder
 Pulling wire or bar stock

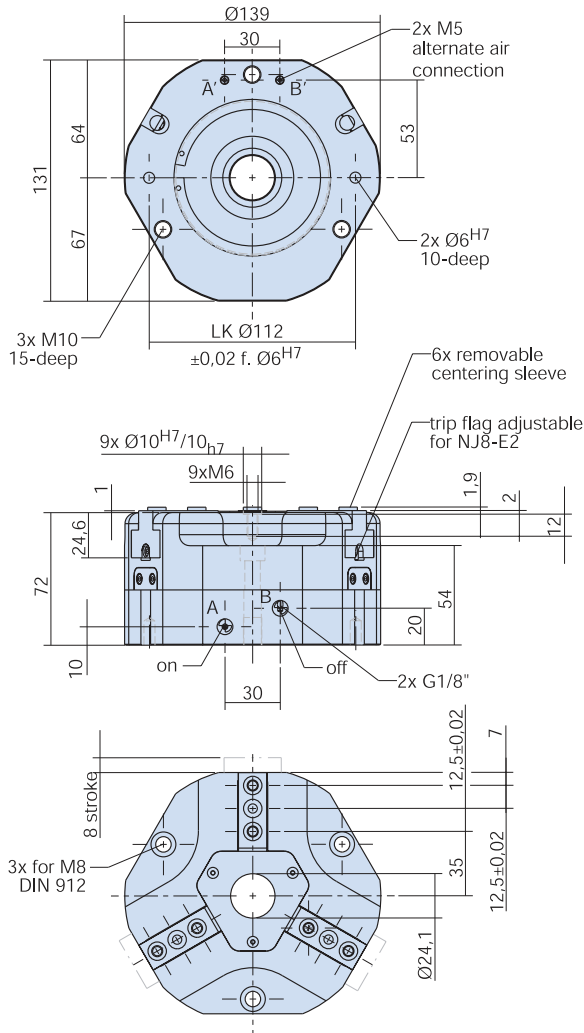
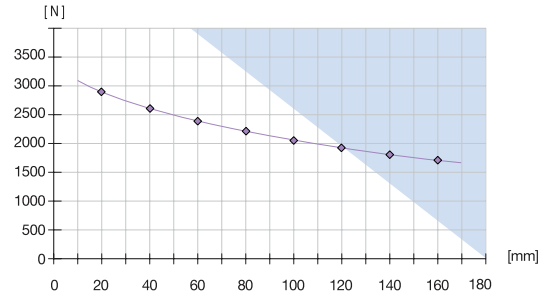

Order no.:				
GD312				
MB				
Drive:				
pneum.				
Stroke per jaw [mm]:				
8				
Gripping force in closing and opening [N]:				
3300				
Self-locking via:				
DSV1/8				
Closing time/opening time [s]:				
0,08				
Repeatability ± [mm]:				
0,05				
Min./max. operating pressure [bar]:				
3/10				
Air volume per cycle [cm ³]:				
127				
Min./max. operating temperature [°C]:				
5/80				
Temp. resistant version up to 150° C [add to part number]:				
T3				
Piston diameter [mm]:				
83				
Weight [kg]:				
3,2				

All data measured at 6 bar.