

Backlash-free safety couplings

Product information

Optimal safety has a name:

GERWAH® Backlash-free safety couplings

Guaranteed by two systems:

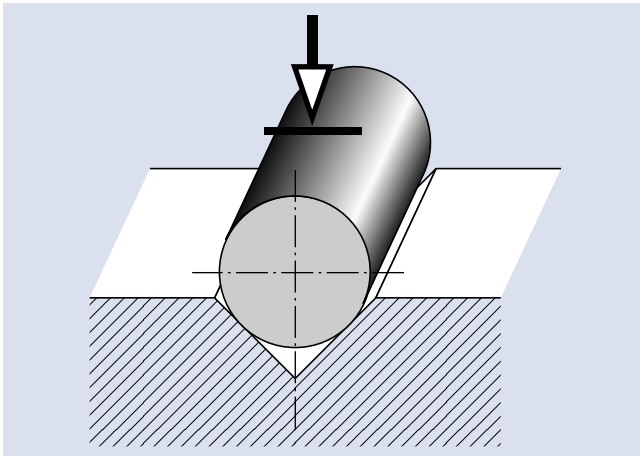

Locking element - cylinder roller
for low, medium and high dynamic loads

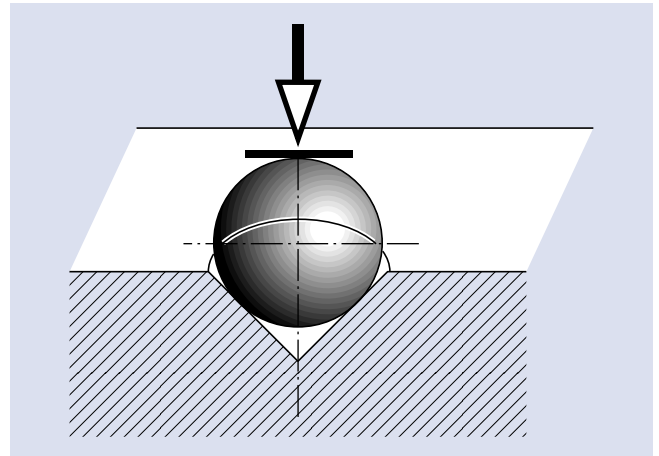

Locking element - ball
for low and medium dynamic loads

GERWAH® Backlash-free safety couplings are delivered ready for installation. They are partly protected by an environment-friendly protective coating. The standard backlash-free safety couplings have borings according to ISO-H7 fitting. We recommend a transition fitting, e.g. H7/j6, for the shafts. If other shaft fittings are used, the fitting tolerance may not exceed a maximum of 0,03 mm.

Power is transmitted between the coupling hub and shaft by compression and friction between the contact surfaces. Special attention must therefore be paid to the tightening torque, the retaining screws, and the perfect condition of the contact surfaces. The contact surfaces must be free of oil and grease.

The disengaging torque specified in the technical data can only be safely transmitted if all these points are followed. If they are not, a reduction in performance must be accepted.

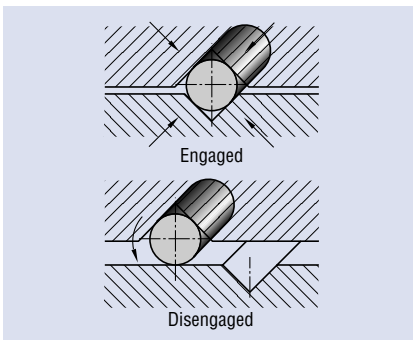

Roller principle

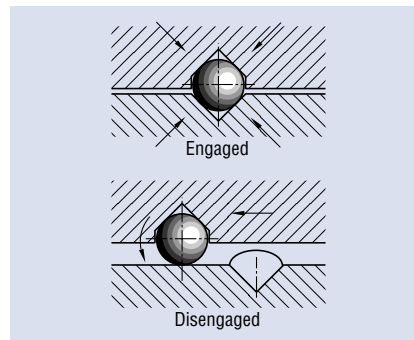

Ball principle

Backlash-free safety couplings

Product information

GERWAH® Backlash-free safety couplings are precision torque limiters with different functional systems for overloads.

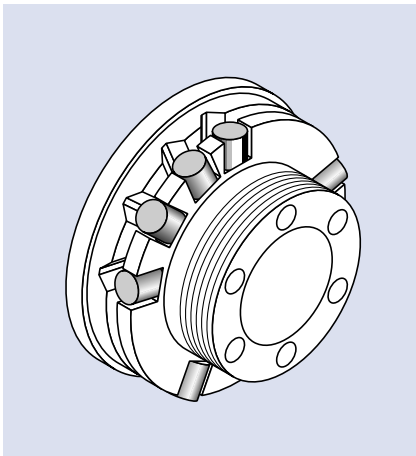

Functional system, synchronizing engagement:

The special indentation geometry for the cylinder rollers or balls only allows the coupling to resume operation after an overload in a particular position, e.g. after 360°. This system is used wherever synchronization after an overload is essential.

e.g. in feeding equipment
in transfer stations
in automation systems

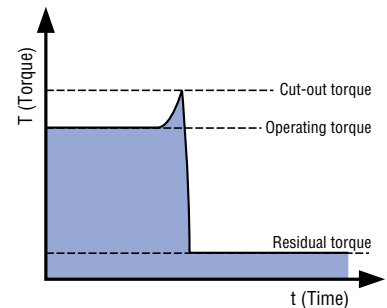

Switching characteristic

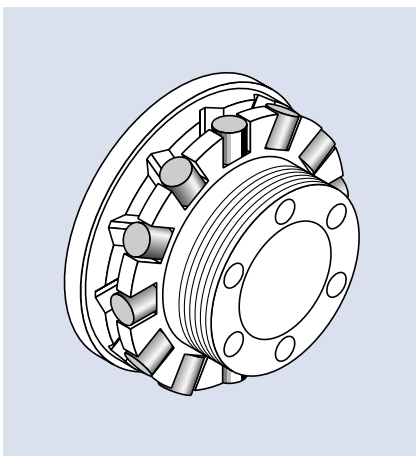

Functional system, continuous engagement

till size 30 → 45°
from size 60 → 60°

The indentation geometry for the cylinder rollers or balls is continuous. After an overload the safety coupling can resume operation in various positions. This system is used wherever synchronization after an overload is of no importance.

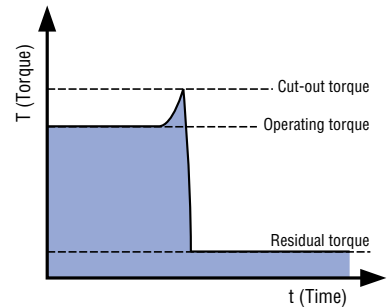

Switching characteristic

Backlash-free safety couplings

Dimensioning

The load limits of our backlash-free safety couplings were determined in extensive series of tests. Two torque ranges are specified for every size. Optimal dimensioning from a technical

and price point of view is therefore possible.

In determining the size of coupling, the cut-out torque defined by the user should lie approximately in the

middle of the coupling's specified torque range. This makes correction of the cut-out torque possible, e.g. during commissioning.

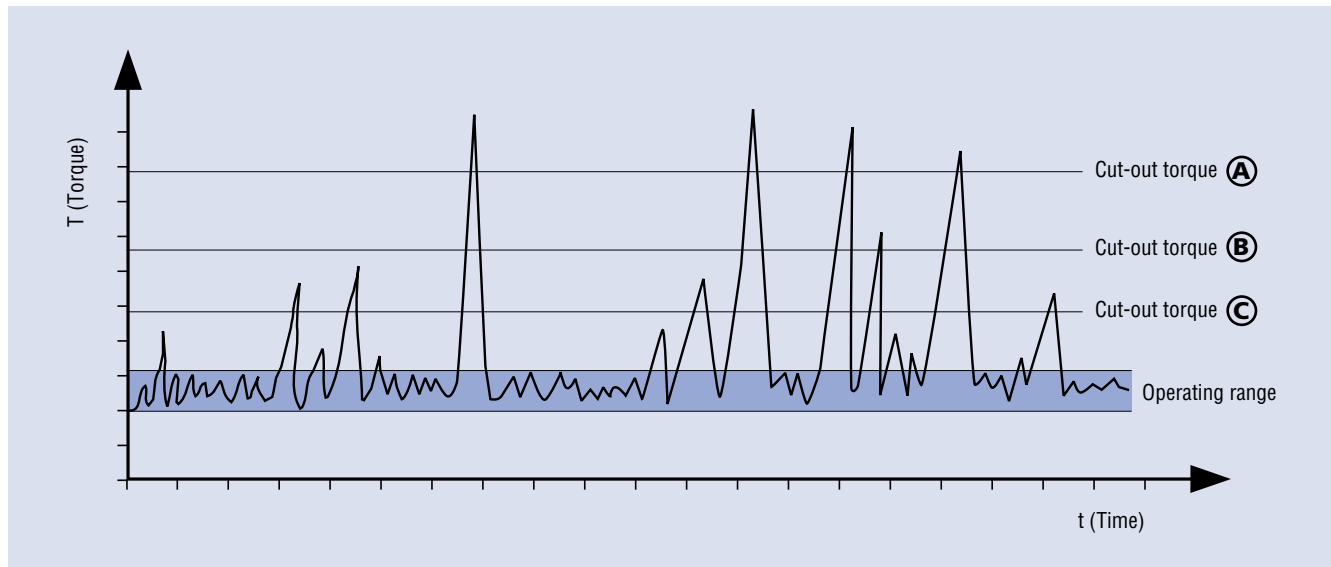

(A) Cut-out torque very high, only extreme load peaks are to be rendered ineffectual. Few cut-outs.

(B) Medium cut-out torque, load peaks strongly reduced. More frequent cut-outs.

(C) Low cut-out torque, virtually no overloads permitted. Many cut-outs.

Locking element used:  or 

Locking element used: 

Dimensioning can also be based on the calculation example on pages 26 and 27.

Our engineering specialists will gladly advise you in the selection and application of couplings. Please contact us for help.

Backlash-free safety couplings

Product information / Customer's advantage

A good concept offers many possibilities

1. Large destructive forces have no effect.

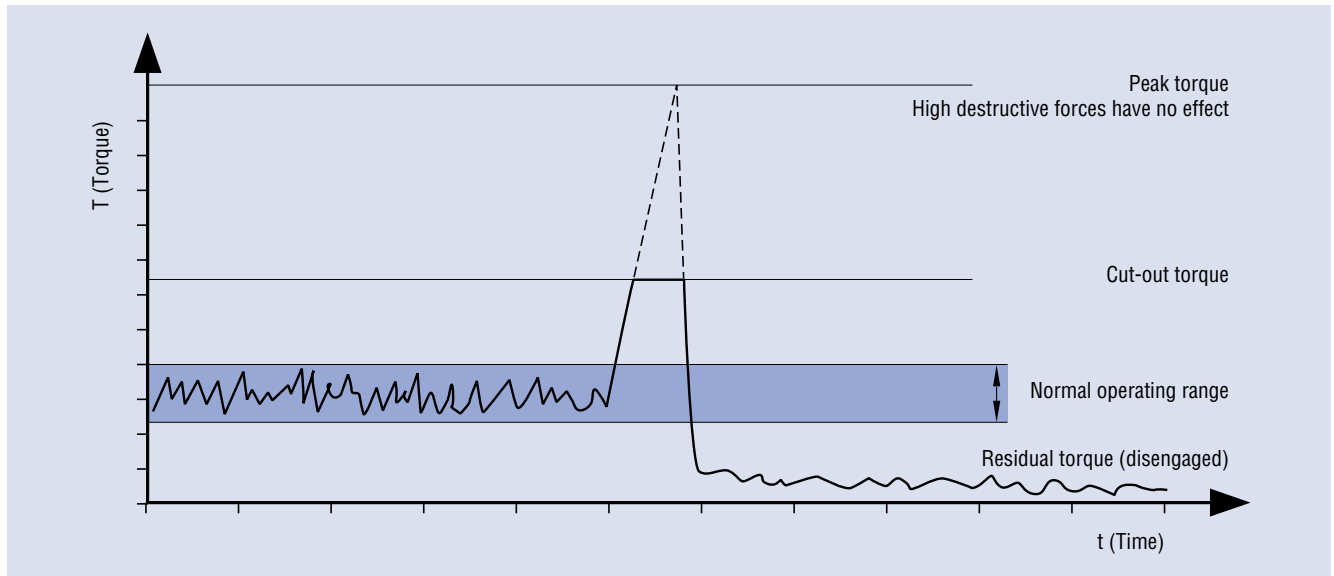

2. In combination with backlash-free servo insert couplings the load characteristic of the motor for the machine can be influenced favourably.

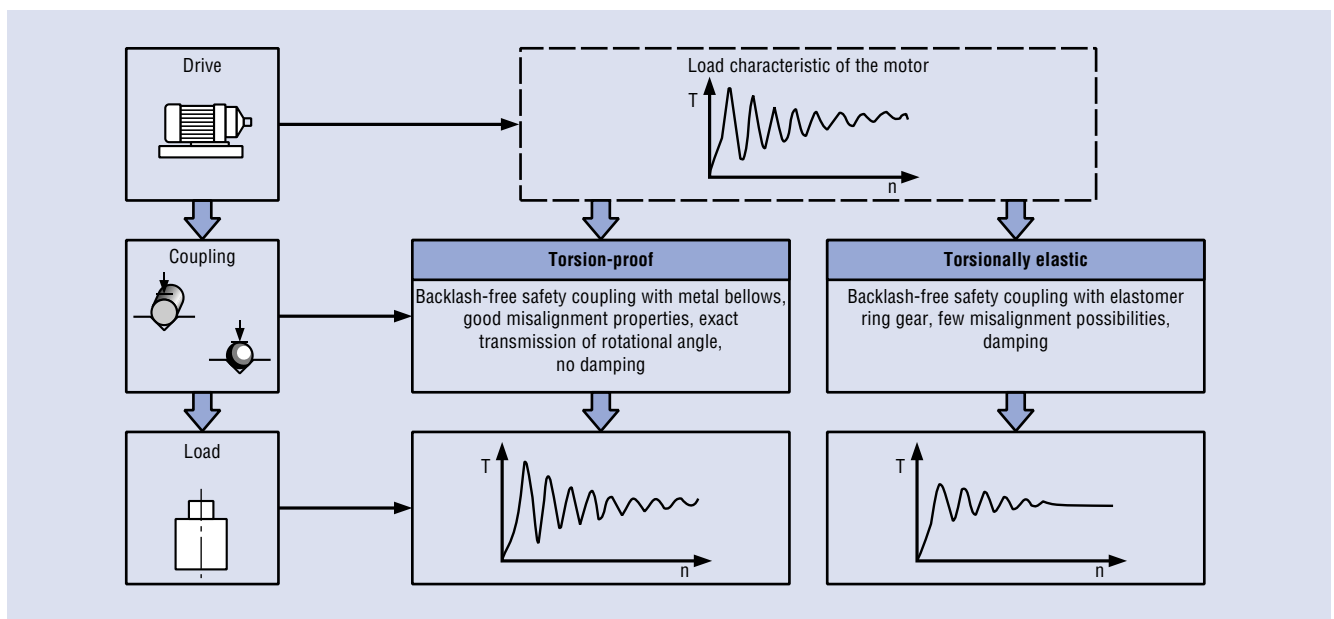

Backlash-free safety couplings

Product information / Customer's advantage

3. What type of machine part do you want to attach?

Spur wheel

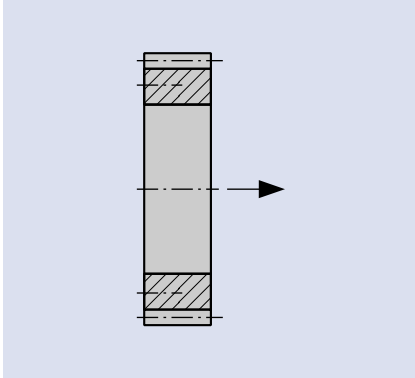

Chain wheel, etc.

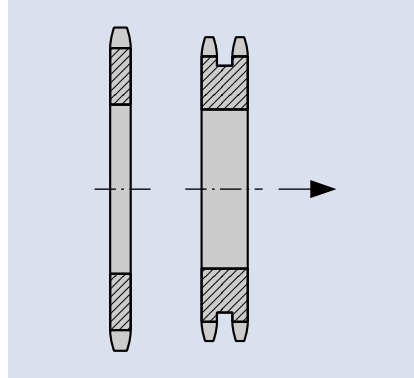

Toothed-belt pulley

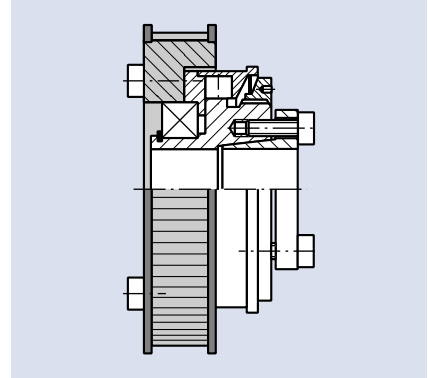

Series DMK/L

4. How do you want to connect the two shafts without backlash?

Safety coupling in combination with:

Torsion-proof metal bellows

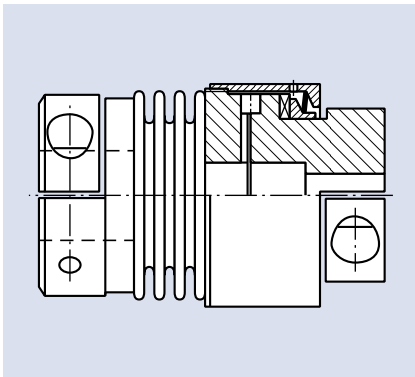

Series DBK/DK

Torsion-proof metal bellows

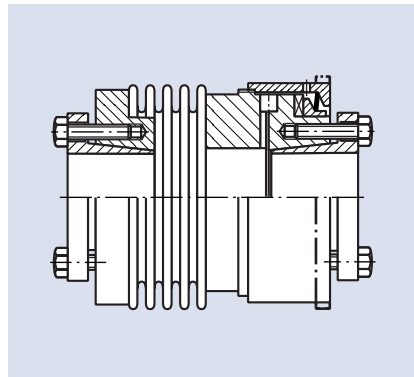

Series DBK/B

Torsion-proof elastomer gear ring

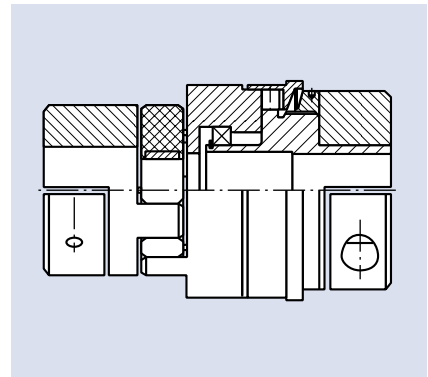

Series DMK/DS

Our coupling systems offer an inexpensive and technically optimal solution for almost every application. Please see overleaf (page 12 and 13) for a quick overview of our series.

Backlash-free safety couplings

Product information

GERWAH® backlash-free safety couplings work as spring-loaded positive couplings. The special roller or ball guides guarantee a totally backlash-free transmission of the torque in both directions of rotation. The couplings are therefore especially suitable for use in speed and direction-controlled drives in conjunction with a closed control loop. Uniform loading of the rollers and balls guarantees high system stiffness, which is important especially for modern servo drives. The roller or ball guides simultaneously guarantee high reliability and switching frequencies when used with high dynamic servo drives.

In the event of an overload the rollers or balls move out of the guides. This results in an axial movement, which activates a proximity switch or limit switch that immediately makes contact to switch off the drive. To avoid damage to the safety coupling, the drive must be switched off immediately after an overload. GERWAH® backlash-free safety couplings were developed for especially dynamic drives operated under constantly changing directions of rotation and under high acceleration. The safety couplings work exclusively with specially selected disk springs with a pronounced degressive

characteristic (see figures 6 and 7). This advantage guarantees shortest switching times (2-4 msec) and a low residual torque, less than 5% in a disengaged state. The coupling disengages immediately when the cut-out torque is exceeded. The torque drops immediately to a small residual value, typically 2 to 5%. The switching work required of our couplings corresponds to only a fraction of that of conventional safety couplings with progressive characteristic (see figure 7). This is a decisive advantage because even ultra-short surges in speed are rendered harmless by the safety coupling.

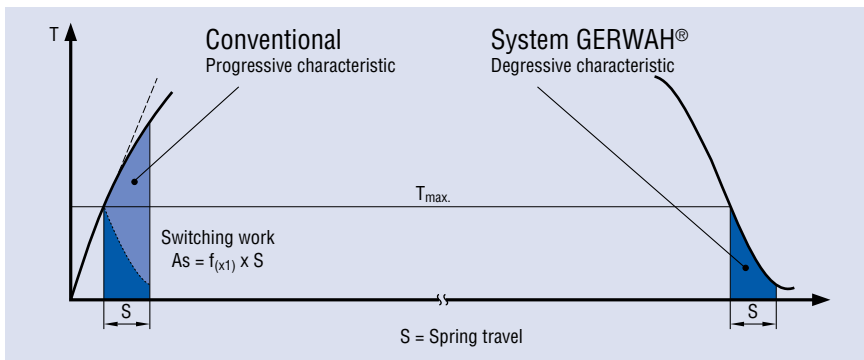

Figure 7: Advantage of System Gerwah®

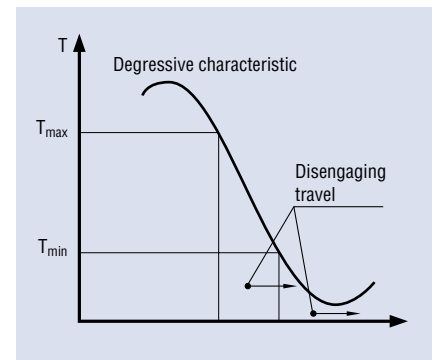

Figure 6: Spring characteristic System GERWAH®

Adjustment of the cut-out torque

GERWAH® backlash-free safety couplings are delivered with set cut-out torque. There are two possibilities for this, namely:

- 1) The user/operator names the cut-out torque in his order.
- 2) The coupling is set on the lowest cut-out torque in its torque range.

Since the handling of disk springs with degressive characteristic regularly causes problems, we would like to explain the adjustment of the cut-out torque in detail.

Figure 8 shows the spring travel we use for our safety couplings.

Point **A** stands for the highest spring force = highest cut-out torque.

Point **B** stands for the lowest spring force = lowest cut-out torque.

Note! The spring travel corresponds approximately to three-quarters of a revolution of the set collar. Every required cut-out torque is progressively adjustable. Due to the degressive characteristic of System GERWAH®, the cut-out torque is reduced when the set collar is turned in

a clockwise direction (towards min.) and raised when turned in an anti-clockwise direction (towards max.). Note! The set collar may only be turned between min. and max.!

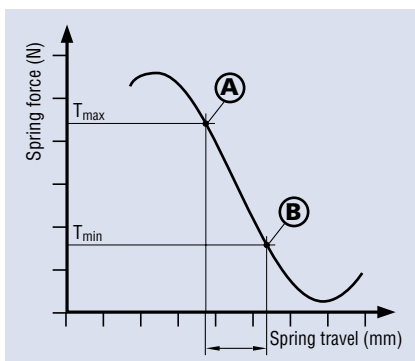

Figure 8

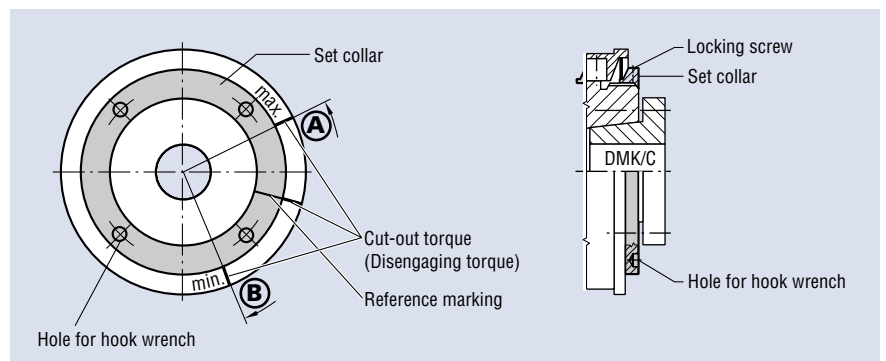

Figure 9

Backlash-free safety couplings

Switches

GERWAH® backlash-free safety couplings produce an axial movement (= disengaging travel) of the outer cover or the ring in the event of an overload (see figures 1 and 2). This

disengaging motion allows a proximity switch or a mechanical limit switch to be activated. This switching signal can be used to switch off the drive and simultaneously

emit an acoustic or optical signal. The switches recommended by us are shown on page 25.

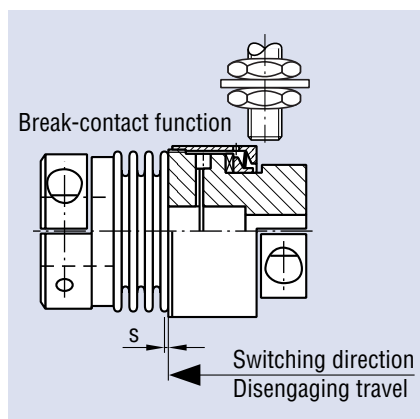

Figure 1: Disengaging travel series DBK/...

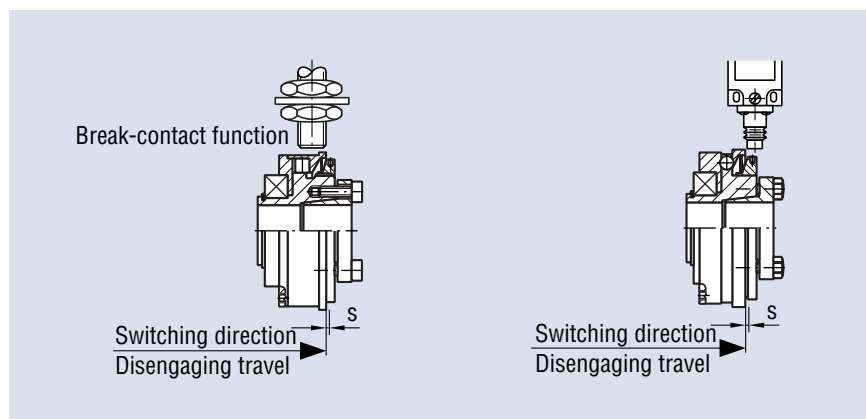

Figure 2: Disengaging travel series DMK/... and DXK/...

Backlash-free safety couplings of the series DBK are delivered up to size 200 with an aluminum outer cover. We recommend a steel ring for the switching signal of a proximity switch, see figure 3.

Backlash-free safety couplings of the series DMK/... and DXK/... are designed to allow direct mounting of a non-contact proximity switch or mechanical limit switch.

Additional steel ring for couplings of the series DBK/...

If required, this additional steel ring is delivered with the safety coupling. It is mounted on the coupling by the manufacturer.

Dimensions

Coupling type	E	Da	b
DBK 7/10	40	50	5
DBK 30	60	65	5
DBK 60	70	80	6
DBK 80/150	92	100	6
DBK 200	100	110	6
DBK 300	110	120	8
DBK 500	128	140	10

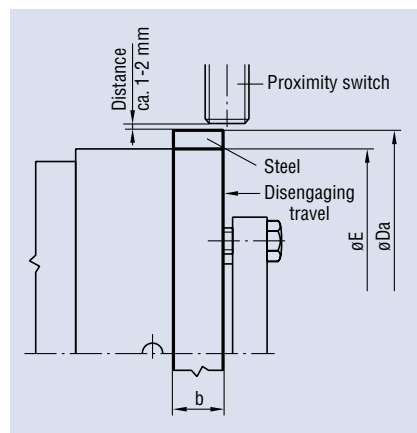

Figure 3: Radially mounted steel ring

Order data

Example: Coupling type

DBK/DK 80 - 32^{H7} - 35^{H7} - 60 Nm - b - SR

Steel ring

Backlash-free safety couplings

Switches / Proximity and Mechanical

Proximity switches

Order data

Proximity switch type:
No. A28-3718-4 – break contact

Dimensions

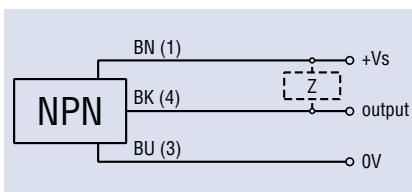
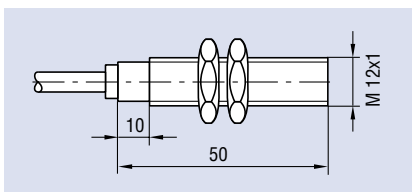

Technical data

Supply voltage: $U = 10 - 30 \text{ V DC}$
 Max. switching current: $J = 200 \text{ mA}$
 Operating temperature:
 $-25 \text{ }^\circ\text{C}$ to $+75 \text{ }^\circ\text{C}$
 Cable connection: 2 m
 System of protection: IP 67
 Switching distance: ca. 1 – 2 mm

Mechanical limit switches

Note: Mechanical limit switches of the type shown below can only be used for safety couplings with a disengaging travel „S“ greater than 1.2 mm.

Order data

Mechanical limit switch type:
No. A28-3796-4

Dimensions

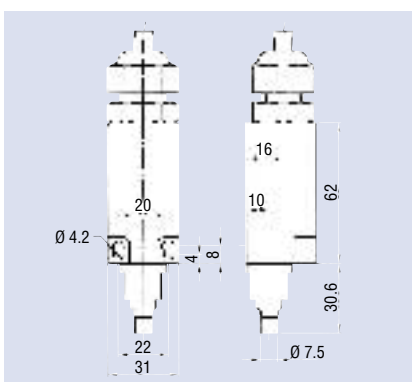

Technical data

Maximum voltage: 500 V AC
 Maximum constant current: 10 A
 System of protection:
 IP 65 according to DIN 40050
 Switching frequency: 6,000/h
 Operating temperature:
 $-30 \text{ }^\circ\text{C}$ to $+80 \text{ }^\circ\text{C}$
 Type of contact:
 1 break contact
 Mechanical life:
 10^7 switching operations
 Housing: Al plastic
 Cover: Al plastic

Limit switch circuit diagram

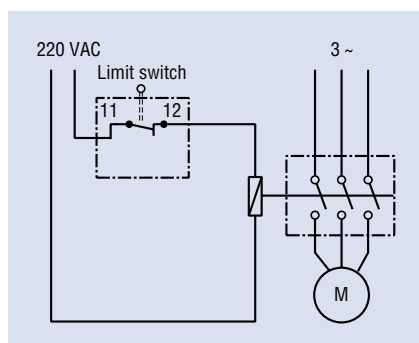

Limit switch mounting

